

Installation Guide Nimbie Sidekick NK50V Disc Caddy Autoloader

GET STARTED

Congratulations on purchasing the Nimbie Sidekick NK50V Disc Caddy Autoloader. NK50V is a state-of-the-art automated disc loader, which requires an Epson Direct-on-Disc printer and software to operate.

NK50V has a 100 discs or more capacity for automated publishing using software such as PrintCD, Windows Painter, PhotoShop, Illustrator, CorelDraw and many others.

Please read this manual carefully before using NK50V. This user guide contains all the information on its operation and maintenance. For additional information please visit our website. We value your comments and suggestions and thank you for your purchase.

Package Contents

Before opening the package, carefully inspect for any damage. If there is any sign of damage, contact the shipping company and your local dealer immediately.

Save the packing materials in case you need to ship or return your product. The original packaging will ensure the product is protected during transportation. Returning goods without the original packaging may not protect the product during transportation, and will void your warranty.

Once you have removed all the parts included with your package please check to see if any pieces are missing or damaged. If any part is missing or damaged, contact your local dealer immediately.

The items listed below should be included in the package:

- One Nimbie Sidekick NK50V (with a disc caddy in it)
- Three extension rods
- One power adapter
- Power cord for power adapter
- One USB cable for NK50V to PC
- One disc caddy as replacement
- One Installation disc
- One stand set
- One assembly guide for stand set
- One installation guide / operation manual

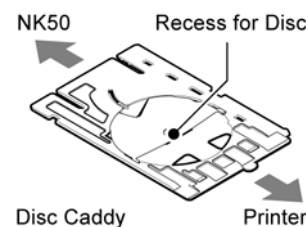

A Look at NK50V

- Extension Rods:
Attach extension rods on the disc loader for 100-disc operation.

- Disc Loader:
Stack the printable discs in this loader (printable side up).

- Output Ramp:
Labeled discs will exit from this slot.

- LED Indicator:

Steady-Green:	Ready
Flashing-Green:	Busy
Flashing Red:	Error

- Loader Cable (NK50V to Disc Loader):
Ensure cable attached at all times

- Latches to Printer (one at each side of NK50V):
These latches shall be inserted into the notches on Epson printer where the front tray shall be attached when labeling discs (refer to Epson printer user manual).

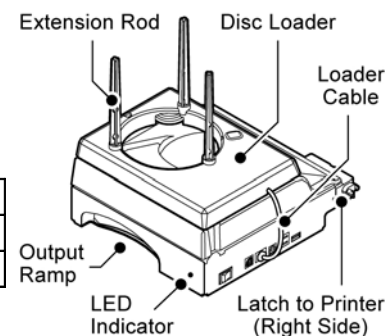

INSTALLATION PROCEDURES

Install Epson Device Driver and software

- 1) Do not attach NK50V on Epson printer.
- 2) Connect Epson printer to PC and complete the installation of Epson printer's device driver and software.
- 3) Insert the front tray to the upper notch on Epson printer (with a CD symbol by it) for disc-labeling operation.
- 4) Set up Epson printer for CD/DVD printing by following the steps below:
 - Click "Start" > "Settings" > "Printer and Fax".
 - Right-click on the Epson printer and choose "Property".
 - Click "Printer Settings" to launch the "Printing Preferences" window.
 - Under Paper Options, select CD/DVD in both the Source and the Type fields.
- 5) Make sure Epson printer itself works fine by running Epson software and manually label a few discs.

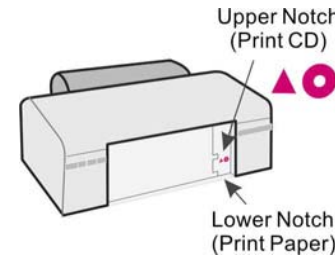

Note:

In case of label misaligned or color mismatched, please refer to Epson manual troubleshooting.

Remove Epson Printer Parts

For NK50V to attach on, both the front cover and the front tray shall be removed from Epson printer (refer to Epson user manual):

- 1) Open the front cover and remove the front tray by lifting it at a 45-degree angle and pulling it outward gently.
- 2) Hold the front cover at sides and press its center downward with thumbs. Concave the front cover to loosen the latches until the cover can be removed from the printer.

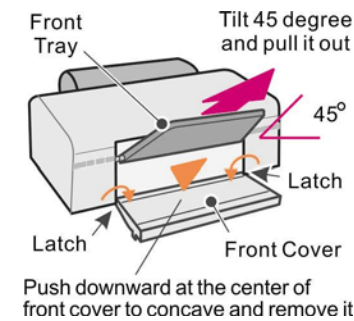

Note:

Keep the front tray and the front cover in case you may need printer service.

Assemble the stand set

For your convenience, NK50V comes with stand set. Please follow the stand assembly guide to get it assembled.

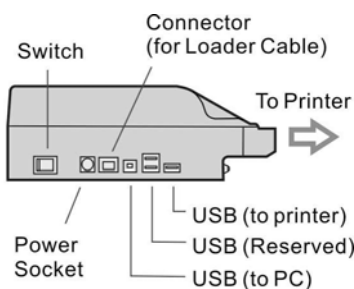

Attach NK50V onto Epson printer

The figure to the right illustrates a complete NK50V system sitting on stand set. Follow the steps below to attach NK50V onto Epson printer:

- 1) Turn NK50V on. Wait until the initialization is complete and the indicator lit up steady-green.
- 2) Close all software programs.
- 3) Use the USB cable that comes with Epson printer to connect it to NK50V.
- 4) Use the USB cable that comes with NK50V to connect it to PC.
- 5) Place Epson printer on Printer Stand.

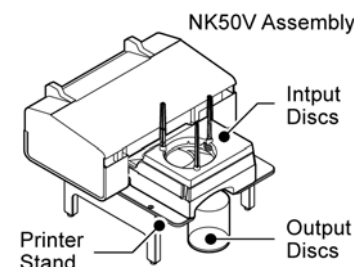

Note:

Stand set with NK50V and Epson printer should be placed on a fairly level surface, flat and firm enough to support the unit and discs.

- 6) Tilt NK50V roughly 45 degrees and carefully align the latches on NK50V to the upper notches on the printer. Insert the latches into the notches to the end. Then, lay down the NK50V to have it sit on the stand set.
- 7) Get a cakebox of 100-disc capacity and place it in front of NK50V to receive output discs.

Install NK50V Device Driver and Utility Software for NK50V

NK50V device driver and utility software MyNK50V are included in the installation disc that comes with NK50V. Follow the steps below to complete the installation:

- 1) Insert the installation disc into an available optical drive on PC.
- 2) After the Main Menu is launched, click Install and follow the on-screen instructions to get NK50V device driver and utility software MyNK50V installed.

Note:
For Windows Vista user, click Run SETUP.EXE on AutoPlay window to start installation. When the User Account Control screen pops up, click Continue.
- 3) After the utility software MyNK50V installation is complete, a "MyNK50V" shortcut shall appear on desktop.
- 4) Remove the installation disc and keep it safe for future use.

Should above procedure failed to get the device driver installed, follow the steps below instead:

- 1) Close all software on PC.
- 2) Turn off NK50V and disconnect its USB cable from PC.
- 3) Turn NK50V on. After initialization complete, connect its USB cable to PC.
- 4) When Windows System alerts you with "Found New Hardware", browse the NK50V installation CD and choose ACAL764.inf as the device driver.

To make sure NK50V device driver has been successfully installed, go to Windows Device Manager and look for NK50V autoloader device in it.

NK50V SYSTEM OPERATIONS

Check Cable Connections

The block diagram below illustrates a NK50V system. Check up the cable connections among the NK50V, the printer and the PC.

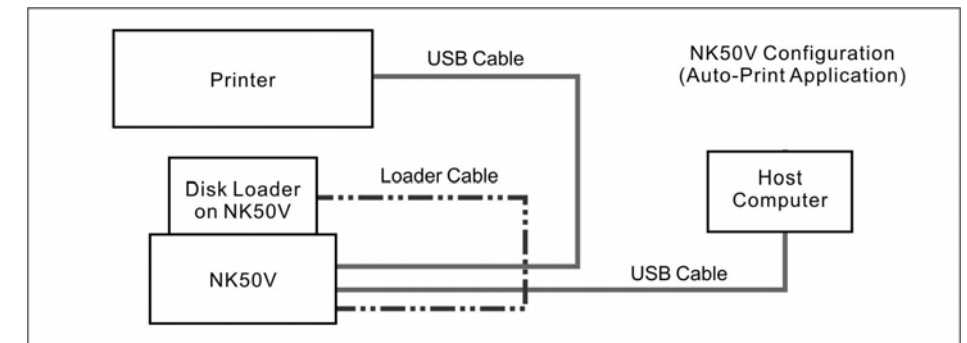

How to turn on NK50V system

Follow the steps below to turn on NK50V system:

- 1) Make sure Epson printer and NK50V are turned off.
- 2) Turn on PC. Do not launch MyNK50V utility software.

Note:

In case MyNK50V is still running, close it by clicking the "Stop NK50V" button on the Main Menu.

- 3) Turn on Epson printer and wait until initialization is complete. The indicator on the printer shall light up steady-green.

Note:

Printer may take up to one minute till initialization is complete.

- 4) Turn on NK50V and wait until initialization is complete. The indicator shall light up steady-green.
- 5) At this moment, the system is hardware ready. You can connect the USB cable from NK50V to the PC.

Note:

During the whole process, in case there is red light on the printer, please turn off NK50V and wait for one minute before turn it on again. Refer to Epson user manual for LED indicator definitions and troubleshooting.

How to turn off NK50V System

Follow the steps below to turn off NK50V system:

- 1) Click the Stop NK50V button on Main Menu of MyNK50V.
- 2) Close MyNK50V.
- 3) Turn off NK50V.
- 4) Turn off Epson printer.
- 5) Turn off the PC.

Start Labeling Discs with NK50V System

When the NK50V system is hardware ready, follow the steps below to start labeling discs:

- 1) Load the NK50V with ink-jet printable discs with the printable side faced up.

Warning:

When the disc loader is empty, do not attempt to load many discs at once.

First, carefully load only one disc into the disc loader and assure it is firmly resting on the three wheels seen in the illustration to the right. You may then gradually load additional discs on top of the first disc, until the loader is full.

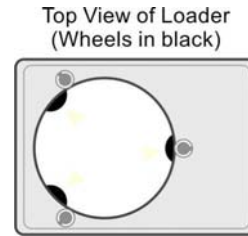

- 2) Launch utility software MyNK50V. Go to Main Menu, click the "Start NK50V" button to activate NK50V.

The system may take up to one minute to detect NK50V. Patiently wait until the status shows ready. The Start NK50V button shall then turn gray when the Stop NK50V button lights up.

Warning:

Before removing NK50V from Epson printer, always click "Stop NK50V" to deactivate the device.

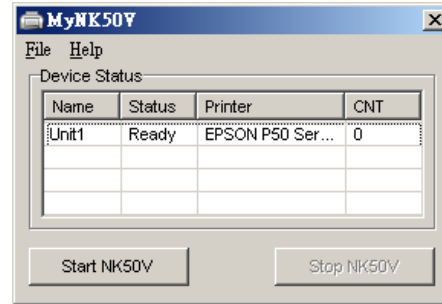

- 3) When NK50V is Ready, you may launch Epson software to label discs:

- Go to Epson software and open or create a disc label file;
- Set up the number of discs to be labeled;
- Start printing

In addition to Epson software PrintCD, MyNK50V also supports other graphic editing software, including PhotoShop, Illustrator, CorelDraw and Windows Paint.

APPENDIX

Replace Disc Caddy of NK50V

The disc caddy will be worn out after a number of disc printings. When printing quality is getting poor, please change the disc caddy.

A spare disc caddy shall come with your NK50V. Or, contact your dealer to purchase additional disc caddies.

Follow the steps below to reject the caddy from NK50V for replacement:

- 1) Click the Stop NK50V button on Main Menu of MyNK50V utility software.
- 2) Keep the cable connections among NK50V, Epson printer and PC.
- 3) Hold NK50V with both hands and tilt its LED end upward to roughly 45 degrees. Then, gently pull it outward off from the printer.

- 4) Give NK50V plenty of room in the front for the disc caddy to come out.

- 5) Go to MyNK50V Main Menu, click File > Reject Disc Caddy. Follow the instructions on the screen to replace the disc caddy.

- After the disc caddy comes out of NK50V, gently pull it outward and remove it from NK50V.
- Insert a new disc caddy into the slot where the old one came out. Push the caddy in until the end is reached.
- Disconnect USB cable from NK50V to PC, turn off NK50V, wait for 15 seconds and turn it on.

Warning:

Do not click the Reject Disc Caddy button while NK50V is still attached onto Epson printer as it may cause permanent damage to the hardware.

- 6) After initialization is complete. Re-attach it back onto Epson printer and turn it on. Reconnect USB cable from NK50V to PC. Wait until the initialization is complete.

Now, try printing a few discs to make sure that replacement caddy is in place.

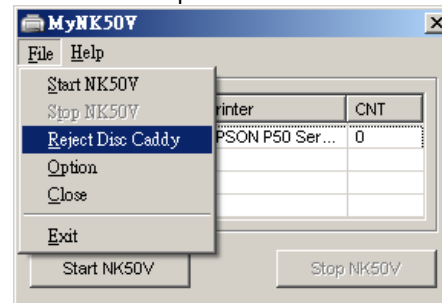

FREQUENTLY ASKED QUESTIONS AND TROUBLESHOOTING

Q: NK50V does not load disc and Epson Printer Status Monitor Windows shows "CD/DVD tray not set correctly"...

- It takes a few seconds before NK50V starts loading disc. Wait patiently.
- Check the disc loader and make sure discs are correctly loaded.
- Check MyNK50V Main Menu and make sure NK50V is ready.
- Avoid direct sunlight.

Q: How to cancel the current printing job...

Before next disc is being loaded into NK50V, go to Epson Printer Status Monitor window, click the Cancel button. Then click the Stop NK50V button on MyNK50V Main Menu.

Q: How to continue printing after the disc loader run out of discs...

Refilling the disc loader with more than 10 discs. NK50V shall automatically detect the discs and continue printing until printing job is done.

Q: How to replace Epson printer cartridge and resume printing...

Go to MyNK50V Main Menu, click the Stop NK50V button. Refer to Epson printer manual to replace cartridge. Then, click the Start NK50V button to resume.

Q: MyNK50V can't detect or activate NK50V ...

- Make sure Epson printer is ready (the LED indicator lights up steady-green).
- Make sure NK50V is ready (the LED indicator lights up steady-green).
- Make sure USB cables are correctly connected among NK50V, Epson printer and PC.
- Make sure the disk loader is attached on NK50V and the loader cable is correctly connected.
- Remove NK50V from Epson printer. Manually print a few discs to make sure printer software is successfully installed.
- Remove NK50V from Epson printer. Refer to Install Device Driver section to make sure NK50V and its device driver are successfully installed.

Q: Epson printer shows error on indicators or error status window...

- Go to MyNK50V Main Menu, click the Stop NK50V button. Turn off Epson printer; wait for one minute and turn it on.
- Detach NK50V from Epson printer. Test the printer itself to ensure proper operation.
- Refer to Epson printer manual for error message and troubleshooting tips.

Q: Disc caddy gets stuck between NK50V and Epson printer...

Follow the steps below to get the disc caddy out of the system:

- Unplug the USB cable, then turn off NK50V and Epson printer.
- Through the opening on NK50V, try to move the disc caddy into NK50V. Or, move it into Epson printer.
- Make sure the disc caddy is completely located inside either the NK50V or Epson printer, then detach NK50V from Epson printer.
- Place NK50V on a flat surface. In case disc caddy is staying within NK50V, push disc caddy inwards with force all the way to the end, then turn on NK50V to have it reposition disc caddy during initialization.
- In case disc caddy is staying within Epson printer, turn on the printer and gently pull the caddy out of the printer. Refer to the Replace Disc Caddy section to re-insert it back to NK50V.
- Re-attach NK50V to Epson printer and set the system to ready.

Q: Discs does not slide out of the output ramp from NK50V...

- If the disc stays on the ramp, clean the ramp surface.
- If the disc gets stuck in disc caddy, clean the caddy's sliding surface or replace with a new caddy. Additional caddies are available for purchasing.

Q: Jammed disc loader or it loads more than one disc at a time...

- Some discs may be sticky and may stuck together. Loose the discs before loading them into the loader.
- Reduce the quantity of discs in the Loader. Try 15 to 20 discs first.
- Use discs of the same brand and lot. Not to mix various disc brands.
- Remove all discs from the loader. Carefully load only one disc into the disc loader and assure it is firmly resting on the three wheels. You may then gradually load additional discs on top of the first disc, until the loader is full.
- Try discs of different brands. Some discs are out-of-specification in diameter or

thickness, or even be distorted.

Q: Loud noise from NK50V when disc caddy is moving...

- Make sure both NK50V and Epson printer are being well placed.
- Make sure NK50V is correctly attached onto Epson printer.
- NK50V may need hardware service. Contact technical support.

Q: NK50V shows error by flashing-red indicator...

- Remove all discs from the disc loader. Make sure no disc left in disc caddy.
- Make sure that disc caddy doesn't get stuck between NK50V and Epson printer.
- If the disc caddy stuck between NK50V and Epson printer, please refer to the previous troubleshooting tips to reset the disc caddy.
- Reinstall NK50V (refer to the Hardware Installation section).

SPECIFICATION

Loader Capacity:	100 discs with extension rods attached
Operation System:	Device driver and utility software MyNK50V support Windows XP, Vista and Windows 7
Supported Printer:	Epson's 6-color, individual ink, photo-quality direct-on-disc printers, including: Artisan 50, Stylus P50, T50, T60, R280, R285, R290, EP-301, EP-302, PM-G860...
Disc Caddy:	Dedicated for NK50V and Epson printer use. Additional disc caddy as spare parts are available for purchasing.
Disc Size:	120 mm in diameter
Temperature:	42°F to 86°F (6°C to 30°C)
Humidity:	5% to 85%, no condensation
Certifications:	CE and FCC; power adapter is UL approved
Dimensions:	249 mm x 254 mm x 248 mm; 9-1/4" x 10" x 9-1/4"
Weight:	5 lbs; 2.2 kg
Power:	100 to 240VAC; 50 or 60 Hz.

OPTIONS

Part Number:	Description
NK50V2Y-BRIDGE	Converter kit, turn NK50V to NK50Y
NK50-EP50-CADDY02	Disc caddy for NK50, twin pack
NK50-EP50-CADDY10	Disc caddy for NK50, ten pack
NK50V-STANDSET	Stand set for NK50V

FCC REGULATIONS

This equipment has been tested and founded to comply with the limits for a Class A digital device, pursuant to Part 15 of the FCC rules. These limits are designed to provide reasonable protection against harmful interference in a residential installation. This equipment generates, uses, and can radiate radio frequency energy. If this equipment is not installed and used according to the instructions, it may cause damaging to the radio communications. However, there is no guarantee that interference will not occur in a particular installation. If this equipment does cause harmful interference to radio or television reception, which can be determined by turning the equipment off and on, the user is encouraged to correct the interference by one or more of the following measures:

- Reorient or relocate the receiving antenna.
- Increase separation between equipment and receiver.
- Connect equipment to an outlet on a circuit different from that to which the receiver is located.
- Consult your dealer or an experienced radio/TV technician.

Any changes or modifications to this device that are not expressly approved could void the user's authority to operate this equipment.

Use of a shielded interface cable is required to comply with the Class A limits of Part 15 of FCC rules.

TECHNICAL SUPPORT

Visit Acronova Knowledge Base on website at <http://www.acronova.com/kb/> and select NK50V to search for questions and solutions.

Always contact the local dealer or authorized service partner for first hand assistance. For further technical support, e-mail us at support-INTL@acronova.com.